

## DAILY PREOPERATIONAL INSPECTION

### **A Transition Stop Device Check:**

Using the little finger, check the function of the Transition Stop Device. Lift shall stop within 4-6 mm (1/6"-1/4") of travel. Once the stop has been initiated, the Transition Stop Device shall move freely and without obstruction until it is hidden under the unloading platform.

### **Check emergency stop (emergency shutdown):**

Test the function of all Stop-buttons. The belt should stop!

### **B Belt Surface Check:**

Operate the chain for at least one complete revolution, check for the following and correct as necessary:

- \* That no chain elements are missing, cracked, or broken.
- \* That all the rubber grommets are present and securely in place.
- \* That each of the splice rods are securely in position and not extending past the edge of the chain surface.
- \* That no excessive gaps or holes exist between the snow and carpet walkways or between the chain and carpet walkways.
- \* That the structural integrity of the carpet-frame has not changed. With the carpet stopped, walk down the centre and check for excessive flex, bending and instability in the frame.
- \* That snow and ice build-up under the drive and return drums have not occurred.
- \* That the entrance-ramp to the belt is maintained level for 2-meters ahead of the belt.
- \* That the unloading ramp is slightly sloping away from the belt for 1,5 – 2 meters.
- \* That excessive build-up of snow and or ice on the carpet hasn't developed that could cause a user to slide backwards.
- \* That each carpet walkway is securely in place and locked-down.

### **C Monitoring Eye (optional)**

Cover up the light source: Chain must stop after 2-4 seconds

### **Arrangement**

In case of a belt damage, or a failure in the safety system stop the belt immediately, until a qualified person repaired it.

If there is a failure in the Monitoring eye it can be by-passed. For the repairtime only direct supervised operation is allowed.

When the weather conditions are critical, hourly, in worst case permanent inspection and maintenance of the loading and unloading area is necessary.

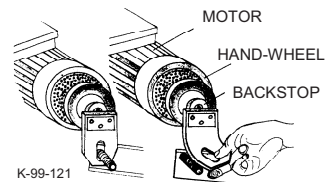
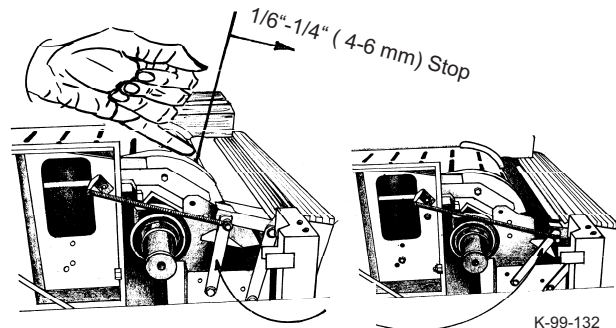

**ATTENTION**  
IF THE CHAIN HAS BEEN MOVED IN BOTH DIRECTION, DON'T FORGET TO PUT IT (RED PLASTIC) BACK INTO WORKING POSITION.

### **CHECK LIST:**

- 1) Transition Stop Device: After 4–6mm (1/6"-1/4") of moving belt must stop
- 2) 100 mm – 5" smooth moving of the Transition Stop Device
- 3) Between the belt and all covering parts (rubber, plastic) a maximum gap of 4 mm (1/6") and minimum gap of 1 mm (1/25") is permitted.
- 4) Belt must stop after pressing any Stop button
- 5) Max. speed – stop – max. stopping distance permitted is 300 mm (12")
- 6) Monitoring eye (optional): Belt must stop after 2-4 sec., if light source is covered.
- 7) Make a run of a total belt round and pay attention to damaged elements and loose rubbers

**Any damage has to be repaired immediately! Otherwise you risk serious accidents with injury to persons!**

### **WEEKLY MAINTENANCE**

- \*Carefully de-icing under the loading and unloading area.
- \*Assurance that the conveyor chain is properly tensioned and operates smoothly otherwise increase chain tension by fixing the tension cord brackets to the next attachment hole.
- \*Test of the back-stop (it must not move in the locked direction)
- \*Check the abrasion of the chain and guide lines. Pay attention of loose screws.

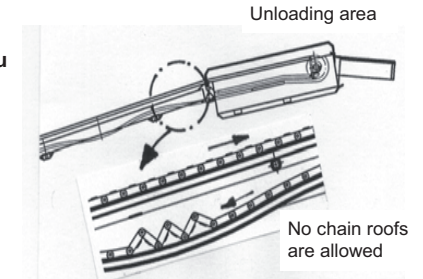

### **GENERAL MAINTENANCE**

General foundation and all structural, mechanical and electrical components shall be inspected regularly and kept in a state of good repair:

#### **A) Conveyor chain:**

- Inspect the chain daily
- No chain -contact with the metal structure is allowed
- No contact with oil or grease
- At the end of the daily operation, cover the chain with a plastic-awning. Make it storm-resistant.

#### **B) Drive and rollers:**

- Rubber surfaces – keep free of oil and grease
- Grease driving-drum-bearing every 200 hours. All other bearings are life time greased
- Keep drums and rollers ice-free

#### **C) Chain -tensioning-system:**

- At the end of the operating season, unhook the rubber cords.
- No contact with oil or grease.

#### **D) Electrical control system:**

- Inspect plugs and wires daily
- At the end of the operating season, store all parts inside

#### **E) Structures:**

- At the end of the operating season, dismantle the structure and store indoors.
- The chain -supporting-surface must be smooth and even. No edges, No gaps. Watch the location of the stainless steel sheets.

#### **F) Gear box:**

- After 5000 operating hours or 5 years the gear oil must be changed.
- Each gear oil for temperatures of –25°C is possible.